

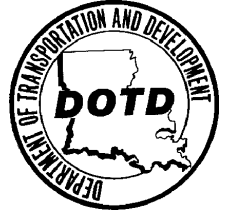

BOBBY JINDAL
GOVERNOR

STATE OF LOUISIANA
DEPARTMENT OF TRANSPORTATION AND DEVELOPMENT
P.O. Box 94245
Baton Rouge, Louisiana 70804-9245
www.dotd.la.gov
Bridge Design Section



WILLIAM D. ANKNER, Ph.D.
SECRETARY

THE POLICIES AND GUIDELINES FOR BRIDGE RATING AND EVALUATION

Prepared by staff of the Bridge Rating Unit,
Under the direction of
Hossein Ghara,
Bridge Design Engineer Administrator

March 3, 2009

Table of Contents

CONTENTS	PAGE
SECTION 1 INTRODUCTION AND GENERAL OVERVIEW	1
1.1 Introduction	
1.2 Purpose of this Document	
1.3 The Load and Resistance Factor Rating Methodology	
1.4 General Load Rating Equation	
SECTION 2 GENERAL LOAD RATING REQUIREMENTS	3
2.1 Load Rating Requirements	
2.1.1 New or Reconstructed Bridges	
2.1.2 Existing Bridges	
2.2 Qualifications and Responsibilities	
2.3 Elements to be Load Rated	
2.4 Analysis and Testing Methods in Load Rating	
2.5 Analysis Tools	
2.6 Concrete Bridges with Unknown Reinforcement	
2.7 Reporting LRFR Ratings to the NBI	
2.8 Evaluation of Concrete Bridges for Shear	
SECTION 3 LOAD AND RESISTANCE FACTOR RATING GUIDELINES	7
3.1 Data Collection for LRFR Load Rating	
3.1.1 Review of Existing Bridge Plans and Documents	
3.1.2 Bridge Inspection for Load Rating	
3.1.3 Assessment of Truck Traffic Conditions at Bridge Site	
3.1.4 Selection of Surface Roughness Rating	
3.2 Live Loads and Load Factors	
3.2.1 Overview of LRFR Load Rating Process for LADOTD Bridges	
3.2.2 Strength Rating for HL-93 Loading	
3.2.3 Strength Rating for AASHTO Legal Loads	
3.2.4 Strength Rating for Specialized Hauling Vehicles	
3.2.5 Strength Rating for Overweight Permits	
3.2.5.1 Standard Annual Permit Vehicles for Load Rating	
3.2.5.2 Standard Single Trip Permit Vehicles for Load Rating	
3.2.6 Reduced Dynamic Load Allowance for Rating	
3.3 Resistance Factors and Resistance Modifiers for the Strength Limit State	
3.3.1 Resistance Factor: ϕ	
3.3.2 Condition Factor: ϕ_C	

3.3.3	System Factor: ϕ_s	
3.4	Resistance Factors and Resistance Modifiers for the Service Limit States	
3.5	Service and Fatigue Limit States for Load Rating	
3.5.1	General Overview	
3.5.2	Concrete Bridges	
3.5.3	Steel Bridges	
SECTION 4	LRFR LOAD POSTING GUIDELINES	24
4.1	Load Posting Requirements for Bridges	
4.2	Reliability-Based Posting	
4.3	Posting Analysis	
SECTION 5	LOAD RATING DELIVERABLES	26
5.1	Load Rating Report	
5.2	Load Rating Summary Sheet	
5.3	Quality Control and Quality Assurance Review of Load Ratings	
5.4	Quality Control of Load Postings	

REFERENCES

PREFACE

The Louisiana Department of Transportation and Development has written these policies and guidelines regarding the usage of Load and Resistance Factor Rating methodology.

This document was written with the assistance from the Federal Highway Administration. Special thanks go to Dr. Firas Ibrahim, P.E., FHWA Office of Bridge Technology; Mr. Thomas Saad, P.E., FHWA Resource Center; Mr. Arturo Aguirre, P.E., FHWA Louisiana Division and Mr. Bala Sivakumar, P.E., HNTB.

The new bridge rating method itself is in the 2008 AASHTO Manual for Bridge Evaluation, first edition. Starting this year, all on-system bridges should be rated or re-rated by Load and Resistance Factor Rating (LRFR) method. These policies and guidelines function as the LRFR implementation manual for Louisiana.

Copies of this document may be downloaded from the LA DOTD website under Bridge Design.

Hard copies of this document may be obtained from:
Louisiana Department of Transportation and Development Headquarters Administration Building
– Room 100
1201 Capitol Access Road
Baton Rouge, Louisiana 70802

Mail orders should be sent to:
Louisiana Department of Transportation and Development
General File Unit
P.O. Box 94245
Baton Rouge, Louisiana 70802
Price - \$10.00 per copy

Questions or comments on the contents of this document should be directed to Bridge Rating Unit of the Louisiana Department of Transportation and Development.
Contact Number: (225) 379-1060
E-mail: dana.feng@la.gov

SECTION 1 INTRODUCTION AND GENERAL OVERVIEW

1.1 INTRODUCTION

Bridge load rating is the determination of the live load carrying capacity of a newly designed or existing bridge. Load ratings are typically determined by analytical methods based on information taken from bridge plans supplemented by information gathered from field inspections or field testing. Knowledge of the capacity of each bridge to carry loads is critical for several reasons, including (but not limited to) the following:

- To determine which structures have substandard load capacities that may require posting or other remedial action.
- To assist in the most effective use of available resources for rehabilitation or replacement.
- To assist in the overload permit review process.
- FHWA requires that bridge load ratings be submitted to them annually. The NBIS (Title 23, Code of Federal Regulations, Section 650.313 (c)), requires that load ratings be in accordance with the latest AASHTO Manual. The results are used in conjunction with other bridge inventory and inspection information to determine the Federal Bridge Sufficiency Rating.

1.2 PURPOSE OF THIS DOCUMENT

This document was developed using the American Association of State Highway Officials (AASHTO) *Manual for Condition Evaluation and Load and Resistance Factor Rating (LRFR) of Highway Bridges*, hereinafter referred to as the LRFR Manual, and the new AASHTO *Manual for Bridge Evaluation*, hereinafter referred to as the MBE. This document provides guidance to load rating engineers for performing and submitting load rating calculations, posting bridges for load restrictions, and checking overweight permits using the LRFR methodology. The procedures stated in this document are to provide guidelines that will result in consistent and reproducible load rating inputs and deliverables. This document serves as a supplement to the AASHTO LRFR Manual and the AASHTO MBE and deals primarily with LADOTD specific load rating requirements, interpretations, and policy decisions.

1.3 LOAD AND RESISTANCE FACTOR RATING METHODOLOGY

Load and Resistance Factor Rating is consistent with the LRFD Specifications in using a reliability-based limit states philosophy and extends the provisions of the LRFD Specifications to the areas of inspection, load rating, posting and permit rules, fatigue evaluation, and load testing of existing bridges. The LRFR methodology has been developed to provide uniform reliability in bridge load ratings, load postings and permit decisions. The LRFR procedures provide live load factors for load rating that have been calibrated to provide a uniform and acceptable level of reliability.

1.4 GENERAL LOAD RATING EQUATION

The general rating equation in LRFR (MBE Eq. 6A.4.2.1-1) is given as:

$$RF = \frac{\phi_c \phi_s \phi R_n - (\gamma_{DC})(DC) - (\gamma_{DW})(DW) \pm (\gamma_p)(P)}{(\gamma_L)(LL + IM)}$$

In the LRFR Rating Factor equation:

RF	=	Rating Factor
R_n	=	Nominal member resistance (as inspected)
ϕ_c	=	Condition Factor (Section 3.3)
ϕ_s	=	System Factor (Section 3.3)
ϕ	=	LRFD Resistance Factor
DC	=	Dead load effect due to structural components and attachments
DW	=	Dead load effect due to wearing surface and utilities
P	=	Permanent loads other than dead loads (secondary prestressing effects, etc.)
LL	=	Live load effect of the rating vehicle
IM	=	Dynamic load allowance (Section 3.2)
γ_{DC}	=	LRFD load factor for structural components and attachments
γ_{DW}	=	LRFD load factor for wearing surfaces and utilities
γ_p	=	LRFD load factor for permanent loads other than dead loads
γ_L	=	Evaluation live load factor for the rating vehicle (Section 3.2)

The load and resistance factors for evaluation are as provided in MBE Section 6 and Sections 3.2 and 3.3 of this document

SECTION 2 GENERAL LOAD RATING REQUIREMENTS

2.1 LOAD RATING REQUIREMENTS

2.1.1 New or Reconstructed Bridges

Load ratings by the LRFR method, for the live load models defined in Section 3.2 of this document, are required for all new and replacement bridges, and for all rehabilitation and repair designs involving a substantial structural alteration. LRFR Load rating calculations shall be performed as part of the design process and reflect the bridge as-built or as-rehabilitated. Load rating does not include the future wearing surface as a dead load because it is not part of the as-built condition. When ratings are performed in conjunction with the preparation of design drawings, the load rating results shall be shown on the structural drawings following the structural notes for all new, replaced and rehabilitated bridge projects (LADOTD requires a table summarizing the load rating results for HL-93 and/or certain legal loads and standard permit loads be shown on the bridge plans). It is also recommended that the live load distribution factor used in the design and initial load rating be noted on the structural drawings. Also, the Load Rating Summary Sheet and the electronic input file for use in future re-analyses shall be created by the Design Engineer and provided to the Load Rating Engineer in accordance with the requirements of Section 2.5 of this document.

If the bridge will open to traffic during the rehabilitation, the contractor is responsible to rate the bridge including any construction load and traffic load under the construction condition. The contractor shall provide the rating result to the Load Rating Engineer before construction and in accordance with the requirements of Section 2.5 of this document.

2.1.2 Existing Bridges

The load rating engineer shall review the bridge file after each inspection to see if a new analysis is required. If new analysis is required documentation of that recommendation will be provided to the State Bridge Engineer and Bridge Maintenance Engineer. A re-rating would usually be necessary if any of the following have occurred since the last load rating was completed:

- The primary member condition rating has changed
- Dead load has changed due to resurfacing or other non-structural alterations such as utilities.
- Section properties have changed due to deterioration, rehabilitation, re-decking or other alterations.
- Damage due to vessel or vehicular hits.
- Cracking in primary members.
- Losses at critical connections.
- Significant changes in traffic loadings, traffic volume.
- Specification changes.
- Issuance of overweight permits.
- Bridge is under construction.
- Soil and substructure settlement and slope stability.

All existing bridges that have not been load rated previously shall be load rated at the time of the next inspection using LRFR in accordance with the requirements of this document and the MBE.

2.2 QUALIFICATIONS AND RESPONSIBILITIES

The engineering expertise necessary to properly evaluate a bridge varies widely with the complexity of the bridge. Evaluation in accordance with this Manual shall be performed and checked by suitably qualified engineers in the type of bridges being load rated. It is expected that load rating engineers using LRFR will have a working knowledge of the LRFD Specifications. Load rating analysis is an engineering evaluation that should be dated, signed and sealed by a licensed professional engineer.

The load rating engineer shall provide quality control of all load ratings by requiring that all load rating calculations be reviewed by an engineer, other than the load rating engineer, prior to submittal to the state. Initials of the reviewer shall be placed on each sheet of the calculations. Failure to do this will be grounds for rejection of the submittal by LADOTD.

2.3 ELEMENTS TO BE LOAD RATED

Load rating will include analysis of the following items:

- All elements defined as “primary members” as well as stringer-floorbeam, girder-floorbeam connections, and truss connections.
- Capacity of gusset plates and connection elements for non-redundant steel truss bridges
- Other connections of non-redundant systems.
- Timber and metal bridge decks.
- Concrete decks on non-redundant systems.
- Timber and metal piers elements.
- Integrated hammerhead
- Pile bent elements.

It is not necessary to analyze concrete bridge decks on redundant stringers provided they do not affect the load carrying capacity of the entire bridge.

For slab on girder bridges, the entire bridge superstructure will be rated in Virtis girder system this includes rating of both interior and exterior girders.

Recent FHWA Technical Advisory T5140.29, dated January 15, 2008, recommends that during future recalculations of load capacity on existing non-load path redundant steel bridges, the capacity of gusset plates be checked to reflect changes in condition or dead load, to make permit or posting decisions, or to account for structural modifications or other alterations that result in significant changes in stress levels. Previous load ratings should also be reviewed for bridges which have been subjected to significant changes in stress levels, either temporary or permanent, to ensure that the capacities of gusset plates were adequately considered. Gusset plates and connection elements of existing non-load path redundant steel bridges that have not under gone a load capacity evaluation in the past shall be checked for compliance with Technical Advisory T5140.29.

2.4 ANALYSIS AND TESTING METHODS IN LOAD RATING

Routine load ratings consist of computations made from design plans, as-built drawings, field measurements, and inspection reports based on common analytical methods, such as LRFD distribution analysis. The rater should review the original design plans as the first source of information for material strengths and stresses. If the material strengths are not explicitly stated on the design plans, LADOTD construction and material specifications applicable at the time of the bridge construction shall be reviewed. This may require investigations into old ASTM or AASHTO Material Specifications active at the time of construction. The MBE also provides guidance and data on older bridge types and materials that allows the evaluation of existing bridges without having to resort to their original design specifications.

All bridges shall be rated in accordance with the LRFD load distribution factors. Refined analysis will only be accepted with the express written consent of LADOTD and should not be undertaken without the prior approval of LADOTD Bridge Rating Engineer.

Higher level load ratings consist of routine computations adjusted for actual material properties as determined from field sampling and tests of the materials. Higher level load ratings may also require the use of refined methods of analysis such as 2-D grillage or 3-D finite element models. Refined methods of analysis are justified where needed to avoid load posting or to ease restrictions on the flow of permitted overweight trucks. Some of the newer more complex structures (segmental bridges, curved-girders, integral bridges, cable-stayed, etc.) were designed using sophisticated analysis methods. Therefore a sophisticated level of analysis will be required to rate these structures.

The actual performance of most bridges is more favorable than conventional theory dictates. If directed by LADOTD, the safe load capacity for a structure can be determined from full scale non-destructive field load tests, which may be desirable to establish a higher safe load carrying capacity than calculated by analysis. Refer to the MBE Section 8 (also, AASHTO LRFR Manual Section 8) for information on conducting field load tests and using the results to establish a new or updated load rating. This method of rating will only be accepted with the express written consent of LADOTD. No investigations of this nature should be undertaken without the prior approval of LADOTD Bridge Rating Engineer.

2.5 ANALYSIS TOOLS

Standard analysis tools applicable to LADOTD bridge inventory can maximize efficiency, provide consistency, and also facilitate future revisions of Load Ratings by different parties. To this end LADOTD has specified Virtis as the acceptable load rating software to be used. If a bridge is capable of being defined within the parameters of the Virtis software, it must be rated using Virtis. Use of analysis software or versions other than those listed below is subject to the consent of LADOTD. (STAAD, LUSAS, MDX, CONSPAN, MATHCAD, Excel, Influence Line Programs)

2.6 CONCRETE BRIDGES WITH UNKNOWN REINFORCEMENT

There are bridges for which common analytical methods are not adequate to determine a load rating. For bridges where necessary details, such as reinforcement in a concrete bridge, are not available from plans or field measurements, knowledge of the live load used in the original design, the current condition of the structure and live load history may be used to provide a basis for assigning a safe load capacity. A concrete bridge with unknown details need not be posted for restricted loading if it has been carrying normal traffic and shows no distress. Nondestructive proof load tests can be helpful in establishing the safe load capacity for such structures. In these circumstances, the engineers shall document their recommendation that a bridge does not have to be load tested or load rated in the LADOTD load rating summary form.

2.7 REPORTING LRFR RATINGS TO THE NBI

For all new load ratings based on the LRFR methodology, the load rating data shall be reported to the NBI as a Rating Factor, for items 63, 64, 65 and 66, using the HL-93 loadings.

2.8 EVALUATION OF CONCRETE BRIDGES FOR SHEAR

MBE Article 6A.5.9 states that in-service concrete bridges that show no visible signs of shear distress need not be checked for shear when rating for the design load or legal loads. LADOTD requires that the shear capacity of all existing reinforced and prestressed concrete bridge members, with the exception of concrete slab bridges (COSLAB, COPCSS), shall be evaluated for shear for the design load, legal loads and permit loads.

SECTION 3 LOAD AND RESISTANCE FACTOR RATING GUIDELINES

3.1 DATA COLLECTION FOR LRFR LOAD RATING

3.1.1 Review of Existing Bridge Plans and Documents

As-built plans are contract design plans which have been modified to reflect changes made during construction. As-built plans are used to determine loads, bridge geometry, section and material properties. Shop drawings are also useful sources of information about the bridge. Plans may not exist for some bridges. In these cases complete field measurements will be required. Certain structures or components of structures are built from standard drawings. These standard drawings may have been changed and revised over time. The specific standard drawings used for construction are generally identified in the roadway plans for the project under which the bridge was built. Other appropriate bridge history records, testing reports, repair or rehabilitation plans should be reviewed to determine their impact on the load carrying capacity of the structure.

3.1.2 Bridge Inspection for Load Rating

Bridges being investigated for load capacity must be inspected for condition as per the latest edition of the MBE and the FHWA Bridge Inspector's Reference Manual. Bridge inspections are conducted to determine the physical and functional condition of the bridge; to form the basis for the evaluation and load rating of the bridge, as well as analysis of overload permit applications. The inspector should verify the accuracy of existing plans or sketches in lieu of plans with field measurements. It is especially important to measure and document items that may affect the load capacity, such as dead loads and section deterioration and damage. Only sound material should be considered in determining the nominal resistance of the deteriorated section. Where present, utilities, attachments, depth of fill, and thickness of wearing surface should be field verified at the time of inspection. Wearing surface thicknesses are also highly variable. Multiple measurements at curbs and roadway centerline should be used to determine an average wearing surface thickness. Load factor for DW at the strength limit state may be taken as 1.25 where thickness has been field measured.

3.1.3 Assessment of Truck Traffic Conditions at Bridge Site

LRFR live load factors appropriate for use with legal loads and permit loads are defined based upon the Average Daily Truck Traffic (ADTT) available or estimated for the bridge site. FHWA requires an ADTT to be recorded on the Structural Inventory and Appraisal (SI&A) form for all bridges. In cases where site traffic conditions are unavailable from the bridge file, the DOTD Transportation Planning and Safety Section should be contacted for current ADTT information for the route carried by the bridge or routes with a similar functional classification. ADTT may also be estimated from Average Daily Traffic (ADT) data for the site.

3.1.4 Selection of Surface Roughness Rating

LRFD dynamic load allowance of 33% reflects conservative conditions that may prevail under certain distressed approach and bridge deck conditions. For load rating of legal and permit vehicles for bridges with less severe approach and deck surface conditions, the

dynamic load allowance (IM) may be decreased based on field observations in accordance with MBE Table C6A.4.4.3-1 (See Section 3.2.6). Inspection should carefully note these and other surface discontinuities in order to benefit from a reduced dynamic load allowance.

To ensure proper and consistent selection of dynamic load allowance values in all load ratings, LADOTD has included a new data item in the Bridge Inspection Forms for documenting the surface roughness of the bridge riding surface, with clear guidelines for inspectors on how to assign a rating for this item. Surface Roughness is defined as follows:

Table 1 Surface Roughness Rating

Surface Roughness Rating	Description
3 = Smooth	Smooth riding surface at approaches, bridge deck, and expansion joints
2 = Average	Minor surface deviations or depressions
1 = Poor	Significant deviations in riding surface at approaches, bridge deck, and expansion joints

3.2 LIVE LOADS AND LOAD FACTORS

3.2.1 Overview of LRFR Load Rating Process for LADOTD Bridges

Live loads to be used in the rating of bridges are selected based upon the purpose and intended use of the rating results. Live load models outlined below shall be evaluated for the Strength, Service and Fatigue limit states in accordance with Table 2:

- 1) Design load rating is a first-level rating performed for all bridges using the HL-93 loading at the Inventory (Design) and Operating levels.
- 2) Rate for the state legal loads: LA Type 3, LA Type 3-S2, AASHTO Type 3-3, LA Type 6 and LA Type 8 given in Figure 1. Legal lane loads given in Figure 2 are to be used for spans greater than 200 ft and for negative moment areas.
- 3) Rate for Specialized Hauling Vehicles using the Notional Rating Load (NRL) given in Figure 3. If the NRL RF < 1.0 for a bridge, then rate for the posting vehicles SU4, SU5, SU6, and SU7 given in Figure 4.
- 4) Rate for Louisiana Annual Permits (Off-Road Equipment): OFRD #1, OFRD #2, OFRD #3 given in Figure 5. Table 4 shows maximum load effects for Louisiana Off-Road Equipment.
- 5) Rate for Louisiana Single-Trip Overload Permits: OVLD #1, OVLD #2, OVLD #3 given in Figure 6. Table 5 shows maximum load effects for Louisiana Overload Permits.

Table 2 LRFR Limit States

Bridge Type	Limit State	Design	Legal	SHV	Permits
		HL-93	LA Type 3, LA Type 3-S2, Type 3-3, LA Type 6, LA Type 8 Lane Loads	NRL, SU4, SU5, SU6, SU7,	OFRD #1, OFRD #2, OFRD #3 OVLD #1, OVLD #2, OVLD #3
Steel	Strength I	•	•	•	
	Strength II				•
	Service II	•	•	•	•
	Fatigue	•			
Reinforced Concrete	Strength I	•	•	•	
	Strength II				•
	Service I				•
Prestressed Concrete (non-segmental)	Strength I	•	•	•	
	Strength II				•
	Service III	•	•		•
	Service I				•
Timber	Strength I	•	•	•	•

3.2.2 Strength Rating for HL-93 Loading

The design-load rating (or HL-93 rating) assesses the performance of existing bridges utilizing the LRFD HL-93 design loading and design standards with dimensions and properties for the bridge in its present as-inspected condition. It is a measure of the performance of existing bridges to new bridge design standards contained in the LRFD Specifications. The design-load rating produces Inventory and Operating level rating factors for the HL-93 loading. The evaluation live-load factors for the Strength I limit state shall be taken as given in MBE Table MBE 6A.4.3.2.2-1.

Table MBE 6A.4.3.2.2-1 Load Factors for Design Load: γ_L

Evaluation Level	Load Factor
Inventory	1.75
Operating	1.35

The dynamic load allowance specified in the LRFD Specifications for new bridge design (LRFD Article 3.6.2) shall apply. For design load rating, regardless of the riding surface condition or the span length, always use 33% for the dynamic load allowance (IM).

The results of the HL-93 rating are to be reporting to the NBI as a Rating Factor. HL-93 Inventory, shall be used as the screening level for Louisiana legal loads.

3.2.3 Strength Rating for Legal Loads

In LRFR, load rating for legal loads determines a single safe load capacity of a bridge. The previously existing distinction of Operating and Inventory level ratings is no longer maintained when load rating for legal loads.

The live load to be used in the LRFR rating for posting considerations for routine commercial traffic should be any of the State legal loads LA Type 3, LA Type 3-S2, AASHTO Type 3-3, LA Type 6 and LA Type 8 given in Figure 1. They are sufficiently representative of routine commercial truck configurations in use in Louisiana, and are used as vehicle models for load rating and for bridge posting purposes.

It is unnecessary to place more than one vehicle in a lane for spans up to 200 ft. because the LRFR live load factors provided have been modeled for this possibility (no lane load to be used). For negative moments and for span lengths greater than 200 ft., critical load effects shall be obtained by lane-type legal load models shown in Figure 2.

The evaluation live-load factors for AASHTO legal loads for the Strength I limit state shall be taken as given in Table MBE 6A.4.4.2.3.1-1.

Table MBE 6A.4.4.2.3.1-1 Live-Load Factors, γ_L for AASHTO Legal Loads

Traffic Volume (One direction)	Load Factor for Type 3, Type 3S2, Type 3-3 and lane loads
Unknown	1.80
ADTT \geq 5000	1.80
ADTT = 1000	1.65
ADTT \leq 100	1.40

Linear interpolation is permitted for other ADTT

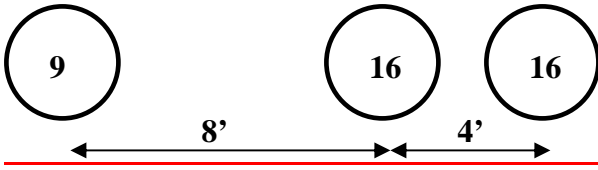

LA Type 3 GVW = 41 kips

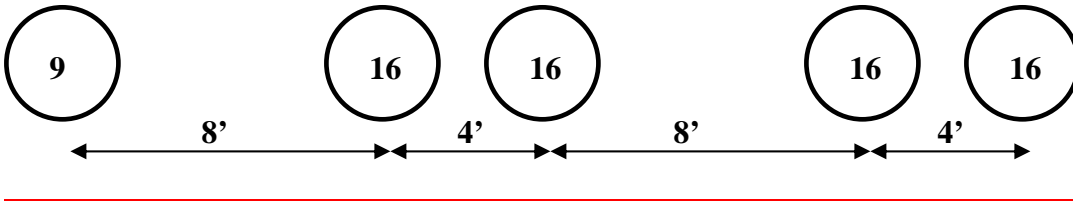

LA Type 3-S2 GVW = 73 kips

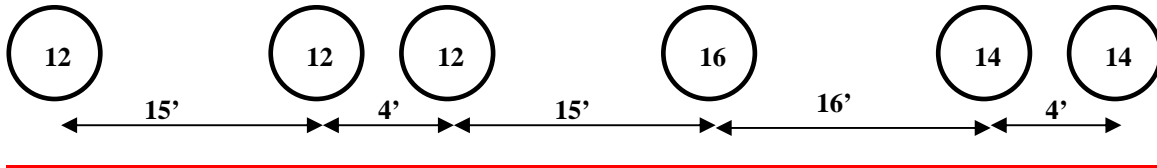

AASHTO Type 3-3 GVW = 80 kips

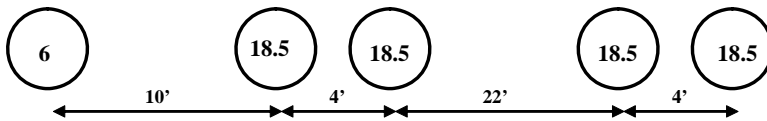

LA Type 6 GVW = 80 Kips

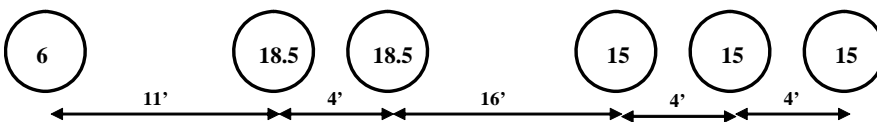

LA Type 8 GVW = 88 Kips

Figure 1. Rating Trucks for Louisiana State Legal Loads

b) Lane-Type Legal Load Model—Apply for spans greater than 200 ft. and all load effects.

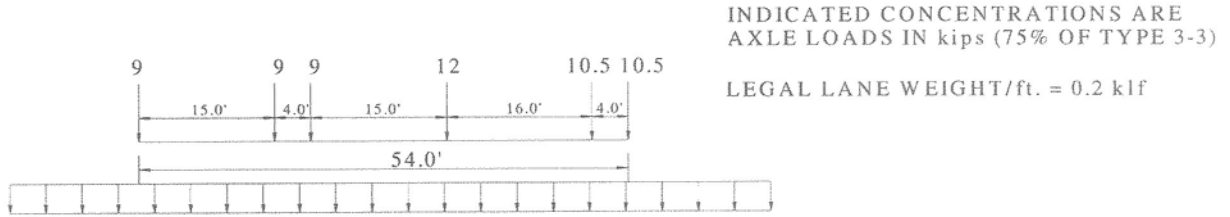

MBE APPENDIX A-6A.4, Figure A-6A.4-4

c) Lane-Type Legal Load Model—Apply for negative moment and interior reaction for all span lengths.

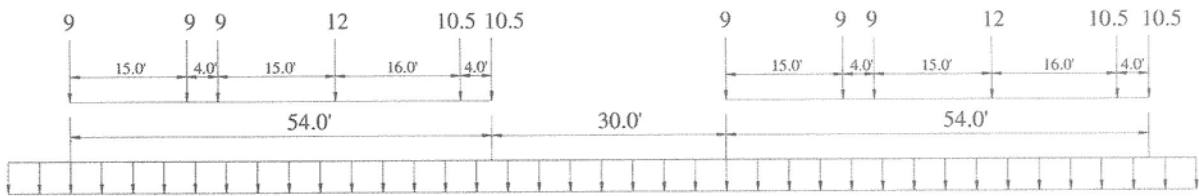

MBE APPENDIX A-6A.4, Figure A-6A.4-5

Figure 2. LRFR Legal Lane Load Models

3.2.4 Strength Rating for Specialized Hauling Vehicles

In recent years, the trucking industry has introduced single unit Specialized Hauling Vehicles (SHV) with closely-spaced multiple axles that make it possible for these short wheelbase trucks to carry the maximum load of up to 80,000 lbs and still meet Federal Bridge Formula B and the axle weight limits. Because of the higher load effects of these vehicles, especially on short span bridges, AASHTO has adopted a new rating live load model and four new single unit trucks as legal loads for bridge posting. The four single unit posting trucks SU4, SU5, SU6 and SU7 shown in Figure 4, model the short wheelbase multi-axle SHVs that are becoming increasingly more common in Louisiana.

The Notional Rating Load (NRL) shown in Figure 3, represents a single load model for load rating that will envelop the load effects of the worst possible SHV configurations with multiple axles on simple and continuous span bridges. Evaluate bridges for this single load model to verify adequate capacity for all SHV traffic. This step is required only as an analysis convenience. There is no requirement to report the NRL rating to the NBI. Bridges that do not rate for the NRL loading shall be investigated to determine

posting needs using the AASHTO single unit posting loads SU4, SU5, SU6, and SU7. LRFD distribution factors are used for the distribution analysis.

The evaluation live-load factors for the NRL and SHV posting loads for the Strength I limit state shall be taken as given in Table MBE 6A.4.4.2.3.2-1.

Table MBE 6A.4.4.2.3.2-1 Live-Load Factors, γ_L for Specialized Hauling Vehicles

Traffic Volume (One direction)	Load Factor for NRL, SU4, SU5, SU6 and SU7
Unknown	1.60
ADTT \geq 5000	1.60
ADTT = 1000	1.40
ADTT \leq 100	1.15

Linear interpolation is permitted for other ADTT.

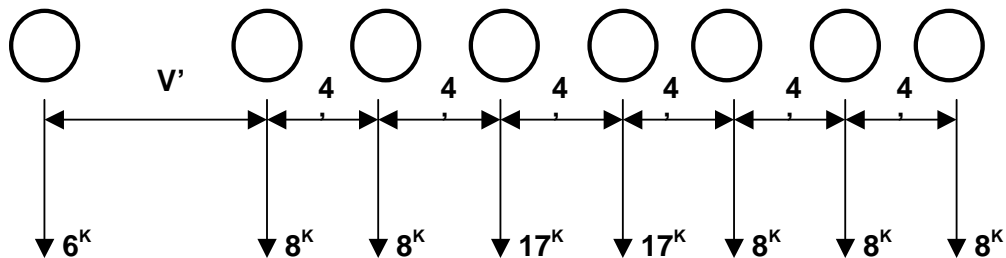

V = VARIABLE DRIVE AXLE SPACING — 6'-0" TO 14'-0". SPACING TO BE USED IS THAT WHICH PRODUCES MAXIMUM LOAD EFFECTS.

AXLES THAT DO NOT CONTRIBUTE TO THE MAXIMUM LOAD EFFECT UNDER CONSIDERATION SHALL BE NEGLECTED.

MAXIMUM GVW = 80 KIPS

AXLE GAGE WIDTH = 6'-0"

Figure 3. Notional Rating Load (NRL) for Specialized Hauling Vehicles

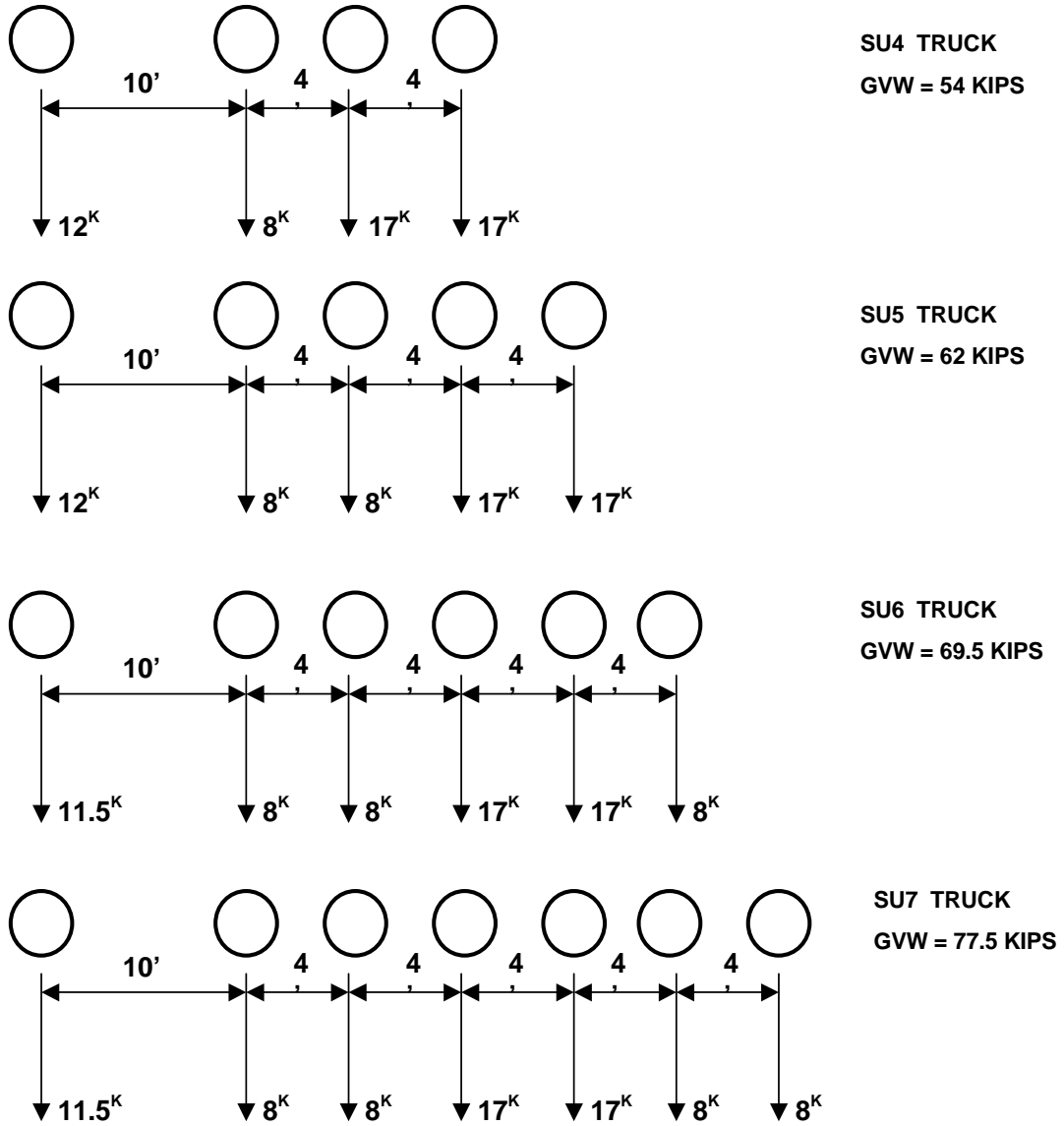

Figure 4. Legal Loads for Posting for Specialized Hauling Vehicles

3.2.5 Strength Rating for Overweight Permits

Single Trip Permits: Permits for single trip movements are issued for one-way or round-trip movement of overweight vehicles. These permits are valid only for the specific date, time, vehicle, and route designated in the permit.

Single trip permit analysis shall be performed for a single lane loading. This is used because these permit loads are infrequent and are likely the only heavy loads on the structure during the crossing. When one-lane LRFDF distribution factor is used, the built-in 1.2 multiple-presence factor should be divided out (That is, divide the computed one-lane distribution factor by 1.2 before using in the permit load rating). The permit vehicle shall be placed laterally on the bridge, within the striped lanes, to produce maximum stresses in the critical member under consideration. In special cases the dynamic load allowance may be neglected provided that the maximum vehicle speed can be reduced to 5 MPH prior to crossing the bridge. Also, in some cases, the truck may be escorted across the bridge with no other vehicles allowed on the bridge during the crossing. If this is the case, then the live load factor can be reduced from 1.5 to 1.15 as shown in Table 3.

Annual Permits: Annual permits are issued for the movement of overweight vehicles over a specified route or within a restricted area. Annual permits are usually valid for unlimited trips over a period not to exceed one year. The permit vehicle may mix in the traffic stream and move at normal speeds without any restrictions. Annual permit analysis shall be performed using distribution factors for two or more lanes loading.

The evaluation live-load factors for permits for the Strength II limit state shall be taken as given in Table 3. (Table MBE Table 6A.4.2.2-1):

Table 3 Permit Load Factors

Permit Type	Frequency	Loading Condition	DF ^a	ADTT (one direction)	Load Factor by Permit Weight ^b	
					Up to 100 kips	≥150 kips
Annual	Unlimited Crossings	Mix with traffic (other vehicles may be on the bridge)	Two or more lanes	>5000	1.80	1.30
				=1000	1.60	1.20
				<100	1.40	1.10
						All Weights
Special or Limited Crossing	Single-Trip	Escorted with no other vehicles on the bridge	One lane	N/A	1.15	
				Single-Trip	Mix with traffic (other vehicles may be on the bridge)	One lane
	=1000	1.40				
	<100	1.35				
	Multiple-Trips (less than 100 crossings)	Mix with traffic (other vehicles may be on the bridge)	One lane	>5000	1.85	
				=1000	1.75	
<100				1.55		

Note: When one-lane distribution factor is used, the built-in 1.2 multiple presence factor should be divided out. Linear interpolation is permitted for other ADTT

3.2.5.1 Standard Annual Permit Vehicles for Load Rating

Standard permit vehicles represent classes of overweight trucks most frequently used to carry loads requiring an Annual Permit. For any bridge re-rating, the standard annual permit vehicles shall be analyzed as additional live load models. The results will be available for informational and future permit management and operations purposes. Analysis is performed using two-lane distribution factors. Figure 5 defines Standard Annual Permits for Louisiana Off-road Equipment. Maximum load effects are given in Table 4. Other Off-Road vehicles heavier than these standard configurations shall be treated as single-trip permits.

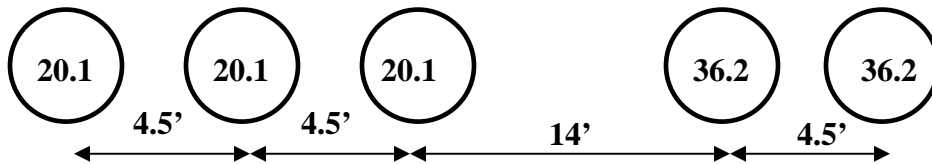

OFRD # 1 Unit Weight = 132.7 kips

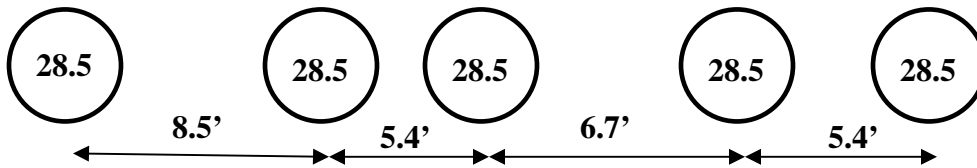

OFRD # 2 Unit Weight = 142.5 kips

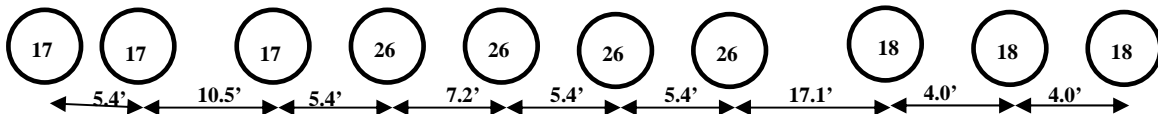

OFRD # 3 Unit Weight = 209.0 kips

Figure 5. Standard Annual Permit Loads for Louisiana Off-Road Equipment

Table 4. Maximum Load Effects for Louisiana Standard Annual Permits

Simple Span (Ft)		20	40	60	80	100	120	160	200
M(+)	HL-93	232.0	578.0	1086.0	1668.1	2317.3	3027.3	4642.4	6515.1
	OFRD#1	281.9	727.1	1374.5	2015.8	2676.4	3339.4	4665.4	5991.3
	OFRD#2	252.9	878.8	1591.3	2303.8	3016.3	3728.8	5153.8	6578.8
	OFRD#3	245.9	795.4	1487.2	2468.4	3513.4	4558.4	6648.4	8738.4
V	HL-93	54.1	67.5	79.4	88.9	97.1	104.1	118.5	132.5
	OFRD#1	65.7	93.9	106.8	113.2	117.1	119.7	122.9	124.9
	OFRD#2	63.9	97.4	112.4	119.9	124.5	127.5	131.2	133.5
	OFRD#3	57.6	90.2	111.8	125.0	141.1	152.4	166.6	175.6

Two Span Continuous (Ft)		20	40	60	80	100	120	160	200
M(+)	HL-93	187.7	466.2	860.3	1325.1	1843.6	2407.3	3688.1	5168.0
	OFRD#1	228.3	562.3	1062.1	1589.8	2121.0	2654.4	3740.8	4837.2
	OFRD#2	193.5	671.3	1249.8	1834.9	2420.1	3008.8	4185.8	5366.3
	OFRD#3	167.8	548.3	1160.5	1935.9	2763.8	3608.1	5311.6	7030.3
M(-)	HL-93	155.1	392.8	803.2	1383.6	1918.4	2492.5	3807.7	5349.6
	OFRD#1	222.5	427.0	660.3	940.3	1210.9	1476.7	2000.4	2518.8
	OFRD#2	204.0	427.3	739.3	1033.7	1320.3	1602.8	2161.8	2716.7
	OFRD#3	187.3	580.0	954.1	1223.8	1664.4	2121.0	2995.8	3843.7
V	HL-93	54.6	74.3	88.0	98.1	107.5	116.4	133.4	149.9
	OFRD#1	86.7	119.7	126.6	129.2	130.4	131.1	131.7	132.0
	OFRD#2	106.7	132.5	137.9	139.9	140.8	141.3	141.8	142.1
	OFRD#3	96.4	148.7	179.5	191.7	197.6	201.0	204.4	206.0

Note: Bold text indicates governing vehicles

3.2.5.2 Standard Single Trip Permit Vehicles for Load Rating

Standard permit vehicles represent classes of overweight trucks most frequently used to carry loads requiring a Single Trip Permit. For any bridge re-rating, the standard single-trip permit vehicles shall be analyzed as additional live load models. The results will be available for informational and future permit management and operations purposes (need not to be used for load restriction purposes).

For most future permit load investigations, the results of the standard permit vehicles will provide a sound basis for screening the load for bridge safety without the need for a new analysis. For specific Single Trip permit applications where the truck may not fit the standard permit configurations, the actual truck configuration described in the permit shall be the live load used to analyze all pertinent structures. Figure 6 defines standard single-trip loads for Louisiana overload permits. Maximum load effects for these standard single -trip permits are given in Table 5. In the future, LADOTD may define additional standard permit vehicles based upon the frequency of such permits and their potential to induce load effects outside the envelope of the other standard permit vehicles.

Single Trip Overweight Permit load analysis assumes only one permit load on the bridge, which allows the use of the single-lane distribution. As stated in the footnote of Table 3, when using a single-lane LRFD distribution factor, the 1.2 multiple-presence factor should be divided out from the distribution factor equations. For girder bridges, the interior and exterior girders shall be checked to see which governs. For single trip permit vehicles, it is important to note that the vehicle could traverse the bridge in any lane, making it necessary to investigate whether the exterior girder controls the load rating.

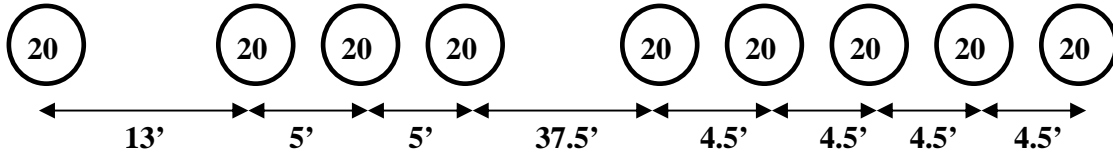

OVLD # 1 Unit Weight = 180.0 kips

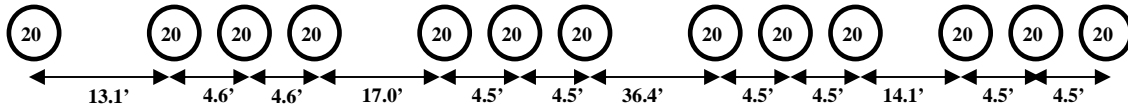

OVLD # 2 Unit Weight = 260.0 kips

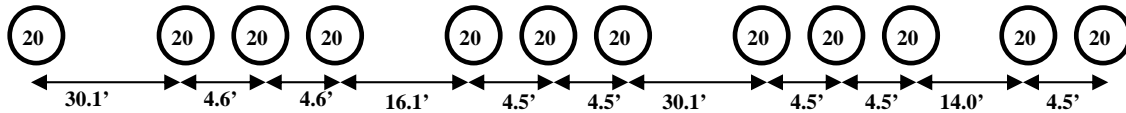

OVLD # 3 Unit Weight = 240.0 kips

Figure 6. Standard Single-Trip Loads for Louisiana Overload Permits

Table 5. Maximum Load Effects for Louisiana Standard Single-Trip Permits (<254 Kips)

Simple Span (Ft)		Wt. (kips)	20	40	60	80	100	120	160	200
M(+)	HL-93		232.0	578.0	1086.0	1668.1	2317.3	3027.3	4642.4	6515.1
	OVLD#1	180.0	230.0	730.0	1230.0	1730.0	2359.2	3180.8	4930.0	6679.2
	OVLD#2	260.0	209.9	540.9	1125.8	1787.3	2487.3	3319.0	5737.0	8305.7
	OVLD#3	240.0	208.4	542.3	1069.8	1654.8	2473.2	3458.7	5773.2	8173.2
V	HL-93		54.1	67.5	79.4	88.9	97.1	104.1	118.5	132.5
	OVLD#1	180.0	55.0	77.5	86.5	103.7	119.0	129.2	141.9	149.5
	OVLD#2	260.0	46.5	71.7	87.8	100.7	117.3	137.5	168.1	186.5
	OVLD#3	240.0	46.0	67.5	85.0	101.7	121.3	137.8	159.2	175.3

Two Span Continuous (Ft)		Wt. (kips)	20	40	60	80	100	120	160	200
M(+)	HL-93		232.0	578.0	1086.0	1668.1	2317.3	3027.3	4642.4	6515.1
	OVLD#1	180.0	175.3	570.3	982.1	1393.2	1889.7	2551.6	3944.4	5382.3
	OVLD#2	260.0	163.0	162.2	434.3	888.9	1368.4	1920.8	2567.0	4515.8
	OVLD#3	240.0			433.9	826.0	1286.9	1920.1	2733.9	4509.9
M(-)	HL-93		232.0	578.0	1086.0	1668.1	2317.3	3027.3	4642.4	6515.1
	OVLD#1	180.0	147.2	468.1	966.0	1292.1	1509.2	1663.5	2388.2	3152.9
	OVLD#2	260.0	180.8	466.2	1029.0	1704.7	2209.7	2581.3	3086.4	4131.8
	OVLD#3	240.0	165.8	453.4	1036.2	1501.8	1903.2	2203.3	2847.8	3927.5
V	HL-93		54.1	67.5	79.4	88.9	97.1	104.1	118.5	132.5
	OVLD#1	180.0	86.8	96.5	129.0	149.7	160.0	165.8	171.8	174.7
	OVLD#2	260.0	68.6	109.9	134.0	181.8	207.5	222.4	238.0	245.6
	OVLD#3	240.0	65.9	102.8	144.7	177.9	198.2	210.1	222.5	228.5

Note: Bold text indicates governing vehicles

3.2.6 Reduced Dynamic Load Allowance for Rating (Legal and Permit Loads)

For legal and permit vehicles rating, of longitudinal members having spans greater than 40 ft. with less severe approach and deck surface conditions, the Dynamic Load Allowance (IM) may be decreased from the LRFD design value of 33%, as given below in Table 6, for the Strength and Service limit states. Dynamic load allowance shall be applied to the state legal vehicles and not the lane loads. Regardless of riding surface condition, always use 33% for spans 40 ft or less and for transverse members. Selection of IM shall be in accordance with the requirements of Section 3.1.4 and the Surface Roughness rating noted in the inspection report. State or document what value of IM was used for the load rating in the Load Rating Summary Form. If the permit vehicle proceeds at a crawl speed, no more than 5 miles per hour, then the impact can be assumed to be 0%.

Table 6 Dynamic Load Allowance for Rating: IM.

Riding Surface Rating	IM
3	10%
2	20%
1	33%

3.3 RESISTANCE FACTORS AND RESISTANCE MODIFIERS FOR THE STRENGTH LIMIT STATES

3.3.1 Resistance Factor: ϕ

For Strength Limit States, member capacity is given as:

$$C = \phi_c \phi_s \phi R_n$$

Where:

ϕ_c = Condition Factor

ϕ_s = System Factor

ϕ = LRFD Resistance Factor

Where, the following lower limit shall apply:

$$\phi_c \phi_s \geq 0.85$$

Resistance factor ϕ has the same value for new design and for load rating. Resistance factors, ϕ , shall be taken as specified in the LRFD Specifications for new construction. A reduction factor based on member condition, Condition Factor ϕ_c , is applied to the resistance of degraded members. An increased reliability index is maintained for deteriorated and non-redundant bridges by using condition and system factors in the load rating equation.

3.3.2 Condition Factor: ϕ_c

The condition factor provides a reduction to account for the increased uncertainty in the resistance of deteriorated members and the likely increased future deterioration of these members during the period between inspection cycles. Current LADOTD policy is to set this factor equal to the values presented in Table MBE 6A.4.2.3-1.

Table MBE 6A.4.2.3-1 Condition Factor: ϕ_c

Superstructure Condition Rating (SI & A Item 59)	Equivalent Member Structural Condition	ϕ_c
6 or higher	Good or Satisfactory	1.00
5	Fair	0.95
4 or lower	Poor	0.85

The Condition Factor ϕ_c does not account for section loss, but is used in addition to section loss. If section properties are obtained accurately, by actual field measurement of losses rather than by an estimated percentage of losses, the values specified for ϕ_c in Table 6A.4.2.3-1 may be increased by 0.05 ($\phi_c \leq 1.0$). For instance, a concrete member may receive a low condition rating due to heavy cracking and spalling or due to the deterioration of the concrete matrix. Such deterioration of concrete components may not necessarily reduce their calculated flexural resistance. But it is appropriate to apply the reduced condition factor in the LRFR load rating analysis. If there are also losses in the reinforcing steel of this member, they should be measured and accounted for in the load rating. It is appropriate to also apply the reduced condition factor in the LRFR load rating analysis, even

when the as-inspected section properties are used in the load rating as this reduction by itself does not fully account for the impaired resistance of the concrete component.

3.3.3 System Factor: ϕ_s

System factors are multipliers applied to the nominal resistance to reflect the level of redundancy of the complete superstructure system. Bridges that are less redundant will have their factor member capacities reduced, and, accordingly, will have lower ratings. The aim of the system factor is to provide reserve capacity for safety of the traveling public. Current LADOTD policy is to use the system factors provided in Table MBE 6A.4.2.4-1 when load rating for Flexural and Axial Effects for steel members and non-segmental concrete members. The system factor is set equal to 1.0 when checking shear. Subsystems that have redundant members should not be penalized if the overall system is non-redundant (i.e. multi stringer deck framing members on a two-girder or truss bridge). System Factor is used with all live load models.

Table MBE 6A.4.2.4-1 System Factor: ϕ_s for Flexural and Axial Effects

Superstructure Type	ϕ_s
Welded Members in Two-Girder/Truss/Arch Bridges	0.85
Riveted Members in Two-Girder/Truss/Arch Bridges	0.90
Multiple Eyebar Members in Truss Bridges	0.90
All Other Girder Bridges and Slab Bridges	1.00
Floorbeams with Spacing >12ft. and Non-Continuous Stringers	0.85
Redundant Stringer Subsystems Between Floorbeams	1.00

Definitions

- Floorbeam – A horizontal flexural member located transversely to the bridge alignment.
- Stringer -- A longitudinal beam supporting the bridge deck.
- Girder – A large flexural member, usually built-up, which is the main or primary support for the structure, and which usually receives load from floorbeams, stringers, or in some cases directly from the deck.

3.4 RESISTANCE FACTORS AND RESISTANCE MODIFIERS FOR THE SERVICE LIMIT STATES

For all non-strength limit states, $\phi = 1.0$, $\phi_c = 1.0$, $\phi_s = 1.0$

3.5 SERVICE & FATIGUE LIMIT STATES FOR LOAD RATING

3.5.1 General Overview

Service and fatigue limit states to be evaluated during a load rating analysis shall be as given below in Table 7:

Table 7 LRFR Service and Fatigue Limit States and Load Factors

Bridge Type	Limit State	Dead Load DC	Dead Load DW	Design Load		Legal Load LL	Permit Load LL
				Inventory	Operating		
				LL	LL		
Steel	Service II	1.00	1.00	1.30	1.00	1.30	1.00
	Fatigue	0.00	0.00	0.75	—	—	—
Reinforced Concrete	Service I	1.00	1.00	—	—	—	1.00
Prestressed Concrete (non-segmental)	Service III	1.00	1.00	1.00	—	1.00	1.00
	Service I	1.00	1.00	—	—	—	1.00

3.5.2 Concrete Bridges

- For non-segmental prestressed concrete bridges, LRFR provides a limit state check for cracking of concrete (SERVICE III) by limiting concrete tensile stresses under service loads. SERVICE III check shall be performed during design load, legal load, and permit load ratings of prestressed concrete bridges. No tension stresses are allowed in the precompressed tensile zone when performing the design load check at the Inventory level. The allowable tensile stress precompressed tensile zone for the Operating level design load check, legal load ratings, and permit load ratings shall be $0.19\sqrt{f'_c}$ in KSI units.
- Service I and Service III limit states are mandatory for load rating of segmental concrete box girder bridges (MBE 6A.5.14).
- A new SERVICE I load combination for reinforced concrete components and prestressed concrete components has been introduced in LRFR to check for possible inelastic deformations in the reinforcing steel during heavy permit load crossings (MBE 6A.5.4.2.2.2). This check shall be applied to permit load checks and sets a limiting criterion of $0.9F_y$ in the extreme tension reinforcement. Limiting steel stress to $0.9F_y$ is intended to ensure that there is elastic behavior and that cracks that develop during the passage of overweight vehicles will close once the vehicle is removed. It also ensures that there is reserve ductility in the member.

3.5.3 Steel Bridges

- Steel structures shall satisfy the overload permanent deflection check under the SERVICE II load combination for design load, legal load and permit load ratings using load factors as given in Table 6. Maximum steel stress is limited to 95% and 80% of the yield stress for composite and non-composite compact girders

respectively. During an overweight permit review the actual truck weight is available, so a 1.0 live load factor is specified.

- In situations where fatigue-prone details are present (category C or lower) a Fatigue limit state Rating Factor for infinite fatigue life shall be computed. If directed by LADOTD, bridge details that fail the infinite-life check can be subject to the more complex finite-life fatigue evaluation using evaluation procedures given in the MBE (Section7).

SECTION 4 LRFR LOAD POSTING GUIDELINES

4.1 LOAD POSTING REQUIREMENTS FOR BRIDGES

NBIS regulations (23 CFR Part 650) require the rating of each bridge as to its safe loading capacity in accordance with the AASHTO Manual for Condition Evaluation of Bridges (MBE) and the posting of the bridge in accordance with this document (MBE) or in accordance with state law, when the maximum unrestricted legal loads or state routine permit loads exceed that allowed under the Operating rating. If a bridge is not capable of carrying statutory loads, it is posted for a lesser load limit. The decision to load post a bridge will be made by the bridge owner based on an agency's load-posting practice. The LRFR guidelines are provided to assist LADOTD and local bridge owners for establishing posting weight limits.

Strength limit state is used for checking the ultimate capacity of structural members and is the primary limit state utilized by LADOTD for determining posting needs. Service and fatigue limit states are utilized to limit stresses, deformations, and cracking under regular service conditions. In LRFR, Service and Fatigue limit state checks are optional in the sense that a posting or permit decision does not have to be dictated by the result. These serviceability checks provide valuable information for the engineer to use in the decision process.

A concrete bridge with unknown details need not be posted for restricted loading if it has been carrying normal traffic and shows no distress (see Section 2.6)..

4.2 RELIABILITY-BASED POSTING

The goal of the LRFR methodology is to maintain target uniform reliabilities in all load ratings and load postings. Unlike past practice, it should be noted that in a reliability-based evaluation the relationship between posting values and rating factors is not proportional. For a posted bridge there is a greater probability of vehicles exceeding the posted limit compared to numbers exceeding the legal limit on an un-posted bridge. The MBE provides guidance on how to translate LRFR rating factors less than 1.0 into posting values that maintain the criteria of uniform reliability, especially for the low-rated bridges. This is achieved through a posting analysis equation, Eq. 6A.8.3-1 and a posting graph given in the MBE that presents posting weights for different vehicle types as a function of LRFR rating factors.

4.3 POSTING ANALYSIS

When for any legal truck the RF is between 0.3 and 1.0, then the following equation should be used to establish the LRFR posting load for that vehicle type:

$$\text{LRFR Posting Load} = \frac{W}{0.7} [(RF) - 0.3] \quad \text{MBE Eq. (6A.8.3-1)}$$

Where:

RF = Legal load rating factor

W = Weight of rating vehicle (Tons)

The Load Rating Engineer shall make a recommendation as to the need for posting and the weight limit for posting should posting be required. When the RF for any vehicle type falls below 0.3, then a recommendation should be made to not allow that particular vehicle type on the bridge.

Other vehicle types with $RF > 0.3$ may continue to use the bridge. Posting recommendations shall be added to the Load Rating Summary sheet.

Bridges that are determined not capable of carrying 3 tons shall be closed.

SECTION 5 LOAD RATING DELIVERABLES

5.1 LOAD RATING REPORT

Load rating calculations and documentation shall be incorporated into a comprehensive report to facilitate updating of the information and calculations in the future. The load rating should be completely documented in writing including all background information such as field inspection reports, material and load test data, all supporting computations, and a clear statement of all assumptions used in calculating the load rating. Sketches shall be provided to document section losses incorporated in the analysis. Inspection reports, testing reports, and articles referenced as part of the load rating shall be documented. When refined methods of analysis or load testing are used, the load rating report shall include live load distribution factors for all rated members, determined through such methods. For more complex structures where computer models are used in the analysis, a copy of the computer models with documentation shall be made and submitted to LADOTD. For new, replaced and rehabilitated bridges designed using LRFD in Louisiana; the LRFR ratings shall be computed at the time of design and shown on the structural drawings following the structural notes.

An electronic version of the load rating report, including the BRASS/Virtis input data file and any computer models used in the analysis, shall be submitted to LADOTD.

5.2 LOAD RATING SUMMARY SHEET

After the structure has been load rated, the LADOTD Bridge Load Rating Summary Form shall be completed and utilized as the first sheet for the load rating calculations.

The summary sheet is also posted on LADOTD Bridge Design website.

Bridge Load Rating Summary

Bridge Data

District	Structure Number	Bridge Name
Parish	Recall Number	Inspection Date
Route	Year Built	Overall
Bridge Posting	Design Load	Deck
Bridge Type	Roadway Width	Super
Bridge Length	Plan Location	Sub
Standard Plan		

Bridge Load Rating Summary

Dead Load	LRFR Evaluation Factors:
Wearing Surface Thickness	Surface Roughness Rating
Wearing Surface Type	Condition Factor
Non-structural attachments	System Factor
	ADTT (one way)

Superstructure/Deck Rating Summary

Vehicle Type	GVW (kips)	Rating Factor	Controlling Member	Controlling Load effect	IM	Live Load Distribution factor
HL-93 (INV)	N/A					
HL-93 (OPR)	N/A					
LA Type 3S2	72.0					
LA Type 3	50.0					
Type 3-3	80.0					
LA Type 6	80.0					
LA Type 8	88.0					
NRL	80.0					
SU4	54.0					
SU5	62.0					
SU6	69.5					
SU7	77.5					
OFRD1	132.6					
OFRD2	142.5					
OFRD3	209.0					

Substructure Rating Summary

Substructure Rated (Y/N) _____

Vehicle Type	GVW (kips)	Rating Factor	Controlling Member	Controlling Load effect	IM	Live Load Distribution factor
HL-93 (INV)						
HL-93 (OPR)						
Legal load						
Permit load						

Posting Analysis Summary

Governing Rating Factor _____
 Governing Load Model _____
 Recommended Posting Load _____

Please Check the following boxes that apply:

- Load rating is not governed by deck
- Load rating is not governed by substructure
- Connections do not control the load rating
- Exterior girder controls the load rating
- Plans do not exist

QC/QA

Rated By: _____ **Remarks/Recommendations**
 Checked By: _____ Project Number _____
 QA By: _____ Rating Software Virtis Others _____
 Date Rated _____

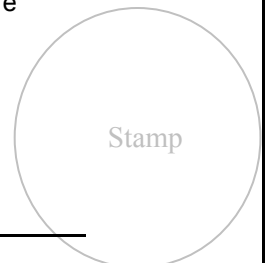

5.3 QUALITY CONTROL AND QUALITY ASSURANCE REVIEW OF LOAD RATINGS

Quality control procedures are intended to maintain the quality of the bridge load ratings and are usually performed continuously within the load rating teams/units. When Consultants perform load ratings, the consultant shall have quality control procedures in place to assure the accuracy and completeness of the load ratings. All load rating calculations shall be checked by a qualified engineer other than the load rating engineer. Upon completion, the initials of the reviewer shall be placed on every sheet of the calculations.

When computer programs are used, the load rating engineer shall perform necessary independent checks to validate the accuracy of the load rating results generated by the program. The checker should verify all input data, verify that the summary of load capacity information accurately reflects the analysis, and be satisfied with the accuracy and suitability of the computer program.

Quality assurance procedures are used to verify the adequacy of the quality control procedures to meet or exceed the standards established by the agency or the consultant performing the load ratings. Quality assurance procedures are usually performed independent of the load rating teams on a sample of their work. Guidance on quality measures for load rating may be found in MBE Article 1.4.

5.4 QUALITY CONTROL OF LOAD POSTINGS

The Bridge Design Section of LADOTD would recommend load posting with concurrence from the District in which the bridge is located. After the bridge is posted by the District, they should be reporting back to the Bridge Section of their action through a memorandum. The Bridge Section should be notified of the District's action within 30 days of receipt of the weight restriction recommendations.

Verification of the posting (or non-posting) shall be confirmed through the bridge inspection reporting. Weight limit signs shall conform to the requirements stated in the MBE.

REFERENCES:

1. AASHTO *The Manual for Bridge Evaluation*.
2. FHWA. 2002. *Bridge Inspector's Reference Manual (BIRM)*, Federal Highway Administration, U.S. Department of Transportation, Washington, DC.
3. AASHTO *LRFD Bridge Design Specifications*, 4th Edition (2007) including all subsequent interim revisions.
4. NCHRP Report 575, *Legal Truck Loads and AASHTO Legal Loads for Posting*.
5. Bridge Gross Weight Formula, U.S. Department of Transportation and FHWA Publication.
6. LADOTD *LRFD Bridge Design Manual*
7. LADOTD *Engineering Directives and Standard Manual (EDSM) I.1.1.8 and I.1.1.15 for Posting and Frequency of Re-rating Policy*.
8. LADOTD *Engineering Directives and Standard Manual (EDSM) IV.4.1.2 for Louisiana Bridge Maintenance-Bridge Inspection and Load Rating Standard*.
9. *Louisiana Legislative Act 35 of 1978 for Posting Advisory Weight Limit Signs*.
10. *Louisiana Legislative Act 686 of 1987 (House Bill No. 1542) for Compliance of Bridge Formula*,
11. *Louisiana Legislative Act 1342 of 1997 (Senate Bill No. 792) for Permit Vehicle, Gross Vehicle Weight, and Axle Load and Spacing Limitation*.
12. *Regulation for Trucks, Vehicles and Loads, latest edition*.
13. *Timber Construction Manual, latest edition and USDA Forest Service Timber Design Specifications*.
14. *National Bridge Inspection Standards*
15. *LADOTD Element Coding Manual*.
16. *LADOTD Pontis Inspection Manual*